

Ultrasonic Cleaning Machines



ULTRASONIC CLEANER
LAVEUSE A ULTRASONS
ULTRASCHALL-REINIGER
LAVATRICE AD ULTRASUONI

CP104

Check the instructions in the rear panel before installing or operating the ultrasonic cleaner

Lire attentivement les instructions au verso avant d'installer et d'utiliser la laveuse à ultrasons

Lösen Sie bitte die Hinweise auf der Rückseite, bevor Sie den Ultraschall-Reiniger installieren oder benutzen

Leggere le avvertenze sul retro prima di installare od operare con la lavatrice ad ultrasuoni



US POWER

99 (%)

- +

US TIMER

10 (min.)

- +

TEMPERATURE

20 (°C)

- +





APPLICATIONS

Dental Labs

Final cleaning of instruments with maximum power and delicate cleaning of cosmetic/corrective prostheses with adjustable power setting.

Hospital/Surgical

Degreasing of surgical instruments, artificial components, etc. Sterilization chemicals can be added to beakers and used in the tank.

Computer

Cleaning of disk drives, chips, p.c. boards etc. Precision cleaning of printer heads, platens, memory cards and other components.

Precision Mechanics

Precision cleaning of critical and delicate components by means of adjustable power settings. Expert cleaning of all types of metal parts including gears, springs, filters, tube, pipe, hinges, ball bearings, brushes.

Jewellery Manufacturing

Removal of investment after casting. Removal of rouge and other buffing and polishing compounds. Removal of oil/grease in chain manufacturing process.

Jewellery Markets

Cleaning of finished goods (watches, chains, rings etc. by the piece or in bulk).

CP102 - CP104

CEIA specializes in the manufacture of Ultrasonic Cleaning Machines designed to clean products with a high-grade finish such as jewellery, silverware and precision machine parts. Residual grease, abrasive cleaners and oils left in awkward corners and indentations by the machinery used to manufacture these objects are easily removed by the ultrasonic cavitation produced in the cleaning liquid.

Our range includes models to meet all types of requirements, from the needs of the craftsman to industrial applications.

The CP104 model has stepped selection of the cleaning power and time, and also provide constant-temperature heating of the liquid.

The CP102 Digit and CP104 Digit models, on the other hand, offer fine numerical adjustment of all cleaning parameters (power, time and temperature).

*High, Constant
Cleaning Quality,
Power and Repeatability*

*Programmable cleaning power,
temperature and time*

*Reliably constant power
generation, independent of
liquid level and temperature*

*Automatic cut-off in the
absence of cleaning solution*

*All functions are
microcomputer controlled*



- 1 On/Off Main Switch
- 2 Activation of ultrasounds
- 3 Regulation of ultrasonic power
- 4 Regulation of cleaning time
- 5 Regulation of cleaning temperature
- 6 Power level display
- 7 Cleaning time display
- 8 Cleaning temperature display
- 9 On/Off Heating
- 10 On/Off Main Switch, Activation of ultrasounds and Regulation of ultrasonic power
- 11 Degassing activation (automatic on the Digit versions)

MODEL	CP102 DIGIT	CP104 Standard	CP104 DIGIT
Bath dimensions (LxWxD)	235 x 135 x 100 mm	235 x 135 x 145 mm	
Bath capacity	2,5 litres	4 litres	
Power absorbed	270W	300W	400W
Power produced	70/140W	100/200W	
Heating power	200W		300W
External dimensions (LxWxD)	320 x 220 x 280 mm		
Weight	4.2 Kg	4.4 Kg	
Nominal frequency	39 kHz		
Power supply	115/230V AUTO -15% / +10%, 50-60HZ with automatic switching		

CP316 - CP831

Models CP316 Digit and CP831 Digit are usually used in goldsmithery and costume jewellery workshops, dental technicians' laboratories, hospital departments responsible for washing surgical instruments and analysis test-tubes (before sterilisation), precision mechanical workshops, spectacle-frame manufacturing and optical laboratories.

The **CP316 Digit and CP831 Digit Cleaners** use a **microprocessor-controlled ultrasound generation system**. This regulates the energy supplied to the transducer unit dynamically, so as to obtain the maximum cleaning power, optimum performance and long life for the transducers themselves.

All cleaning parameters (power, time and temperature) are digitally adjustable, and their current settings are shown on individual displays.

The Cleaners' casing is entirely in **INOX stainless steel**, and therefore offers long-lasting strength and reliability.

*High, Constant
Cleaning Quality,
Power and Repeatability*

*Programmable cleaning power,
temperature and time*

*Reliably constant power
generation, independent of
liquid level and temperature*

*Automatic cut-off in the
absence of cleaning solution*

*All functions are
microcomputer controlled*



- 1 On/Off Main Switch
- 2 Activation of ultrasounds
- 3 Regulation of ultrasonic power
- 4 Regulation of cleaning time
- 5 Regulation of cleaning temperature
- 6 Power level display
- 7 Cleaning time display
- 8 Cleaning temperature display

MODEL	CP316 DIGIT	CP831 DIGIT
Bath dimensions (LxWxD)	400 x 250 x 175 mm	400 x 250 x 340 mm
Bath capacity	16 litres	31 litres
Power absorbed	900W	1800W
Power produced	300/600W	800/1600W
Heating power	600W	1300W
External dimensions (LxWxD)	500 x 350 x 400 mm	500 x 350 x 550 mm
Weight	19 Kg	23 Kg
Nominal frequency	40 kHz	
Power supply	115/230V AUTO -15% / +10%, 50-60HZ with automatic switching	

USCM 1G 1200 - 1400 - 2400

These models are designed to solve industrial-scale cleaning problems where thorough cleaning is required, perhaps before plating.

The single-bath models **USCM 1G 1200 (60 litres)** and **USCM 1G 1400 (90 litres)** respond to the normal needs of precision mechanical industries, plating shops and goldsmithery companies.

Lastly, the single-bath model **USCM 1G 2400 (227 litres)** is recommended for silverware manufacturers (for cleaning plate and candlesticks), for plating shops and for cleaning glass-ware in chemical industries.

High, Constant Cleaning Quality, Power and Repeatability

Continuous adjustment of the cleaning time: from 0 to 15 minutes

Continuous adjustment of the temperature: from 0 to 90°C

4-level power adjustment: 66%, 77%, 89% and 100%

Consistent cleaning quality regardless of the working conditions

Water inlet system controlled by electric switch

Stainless steel construction

Drainage valve



- 1 Heating regulator
- 2 Water supply switch
- 3 Heating indicator lamp
- 4 Water drainage valve
- 5 Ultra-sound timer
- 6 Ultra-sound power regulator
- 7 Main switch
- 8 Power supply indicator

MODEL	USCM 1G 1200	USCM 1G 1400	USCM 1G 2400
Bath dimensions (LxWxD)	580 X 350 X 340 mm	580 X 350 X 430 mm	700 X 500 X 650 mm
Bath capacity	65 litres	85 litres	227 litres
Power absorbed	3700W	3900W	4800W
Power produced	1200/2400W	1400/2800W	2400/4800W
Heating power	2500W	2500W	4800W
External dimensions (LxWxD)	840 X 535 X 990 mm	840 X 535 X 990 mm	1000 X 700 X 1050 mm
Weight		85 Kg	182 Kg
Nominal frequency	39 kHz		
Power supply	230V AC * -15% / +10%, 50-60HZ		

*115V AC version available on request

TD US

CEIA transducers, tried and tested over a long period in the manufacture of Ultrasonic Cleaners, are also produced in an immersion version.

Contained within a waterproof AISI 316 stainless steel casing, they can easily be mounted on the bottom or sides of even large-scale baths, wherever high levels of ultrasonic power are required. These immersion transducer units are piezoelectric with ceramic crystals. Where multiple units are used, the generators are connected to each other via optic fibre, resulting in a overall, synchronised generating system providing great power and cleaning efficiency.



4-level power adjustment:
66%, 77%, 89% and 100%

High efficiency with automatic search of the optimum working point of the system which consists of transducer and tank

Controlled by microprocessor

Possibility of personalising the position of the cable outlet at the customer's request

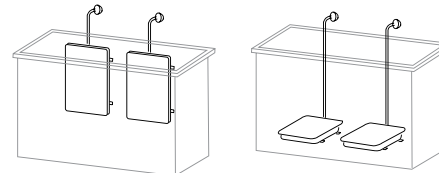
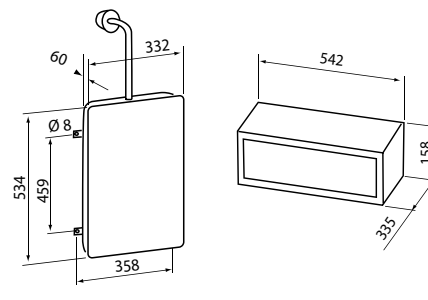

Application examples

MODEL	TD US 1200	TD US 1400
Tank capacity	50 - 70 litres	70 - 120 litres
Generator Power	1200/2400W	1400/2800W
Weight	29 Kg	
Nominal frequency	39 kHz	
Power supply	230V AC * -15% / +10%, 50-60Hz	
*115V AC version available on request		

Accessories



Covers

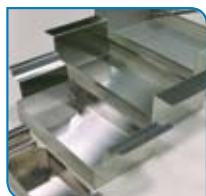

Baskets

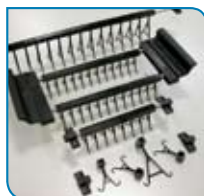

Hook racks



Beakers and beaker-holders



Cleaning solutions (CleanAreX® 1)

Available in 1 l. and 5 l. packaging



Costruzioni Elettroniche Industriali Automatismi

Zona Industriale 54/G, Vicinaggio - 52040 Arezzo (ITALY)

Tel: +39-0575-4181 - Fax: +39-0575-418297

E-mail: infogold@ceia-spa.com

www.ceia.net